

EVOLUTION DU TYPE À LA FICHE  
D'HOMOLOGATION  
EVOLUTION OF THE TYPE TO THE  
HOMOLOGATION FORM

Homologation N°

25/CA/11  
02/02/ET



COMMISSION INTERNATIONALE  
DE KARTING - FIA



Constructeur : GIACOLETTO PIERLUIGI \_\_\_\_\_  
Manufacturer:

Adresse : FRAZIONE PREPARETTO, 127- 10081 CASTELLAMONTE \_\_\_\_\_  
Address:

Marque : KG \_\_\_\_\_ Modèle : DUO \_\_\_\_\_  
Make: Model:

Catégorie : Toutes / All \_\_\_\_\_ Nombre des pages: 1+3 \_\_\_\_\_  
Category: Number of pages:

L' Evolution du Type est prononcée à compter du : 01 janvier 2008 \_\_\_\_\_  
The Evolution of the Type comes into effect on: (à remplir par la CIK-FIA)  
(to be filled in by the CIK-FIA)

**Description :** au moins dans une des deux langues officielles (français-anglais)  
in at least one of the two official languages (French/English)

APPLIED SOME CHANGES IN ORDER TO GIVE THE POSSIBILITY TO USE BIGGER  
RADIATORS.

**JOINDRE : Dessin ou photo des pièces nouvelles selon Fiche d'Homologation**  
**ATTACH: Drawing or photograph of the new parts on the Homologation Form**

Timbre et signature de l'ASN  
ASN's stamp and signature:

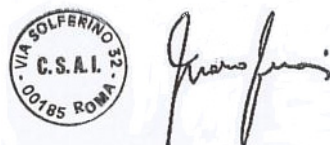

Timbre et signature de la CIK-FIA  
CIK-FIA's stamp and signature:



Date : 20/11/2007

Date : 21/12/2007

# FICHE D'HOMOLOGATION HOMOLOGATION FORM

25/CA/11  
02/02/ET



## COMMISSION INTERNATIONALE DE KARTING – FIA



### CARROSSERIE / BODYWORK

Constructeur	Manufacturer	Giacoletto Pierluigi
Marque	Make	KG
Modèle	Model	DUO
Catégorie	Category	Toutes / All
Durée de l'homologation	Validity of the homologation	6 ans / years
Nombre de pages	Number of pages	3

La présente Fiche d'Homologation reproduit descriptions, illustrations et dimensions au moment de l'homologation CIK-FIA.

*This Homologation Form reproduces descriptions, illustrations and dimensions at the moment of the CIK-FIA homologation.*



PHOTO VUE DE DESSUS DES ÉLÉMENTS DE CARROSSERIE AVEC LEURS SUPPORTS  
PHOTO FROM ABOVE OF BODYWORK ELEMENTS WITH THEIR SUPPORTS

Signature et tampon de l'ASN  
Signature and stamp of the ASN

Signature et tampon de la CIK-FIA  
Signature and stamp of the CIK-FIA



*Giacoletto Pierluigi*



*[Signature]*

**CARROSSERIE LATÉRALE AVEC SUPPORTS**

Dessin technique (dimensions d'encombrement – diamètre et épaisseur des tubes supports)

**LATERAL BODYWORK WITH SUPPORTS**

Technical drawing (bodywork main external dimensions – supports diameter and wall thickness)

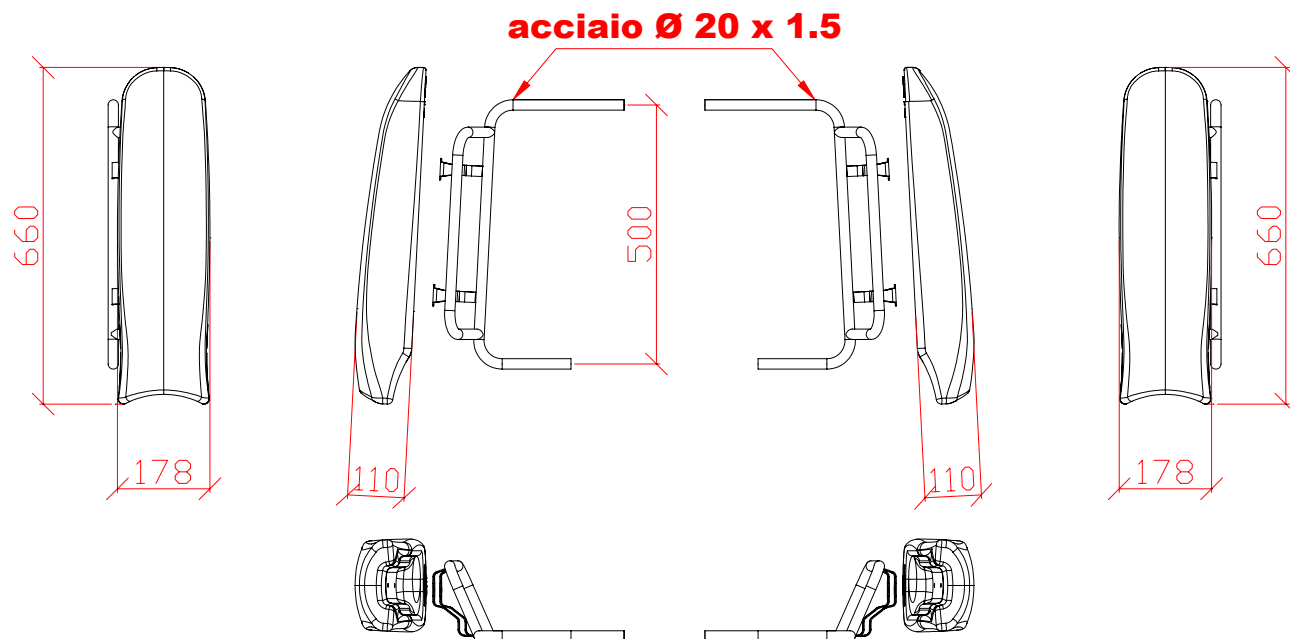
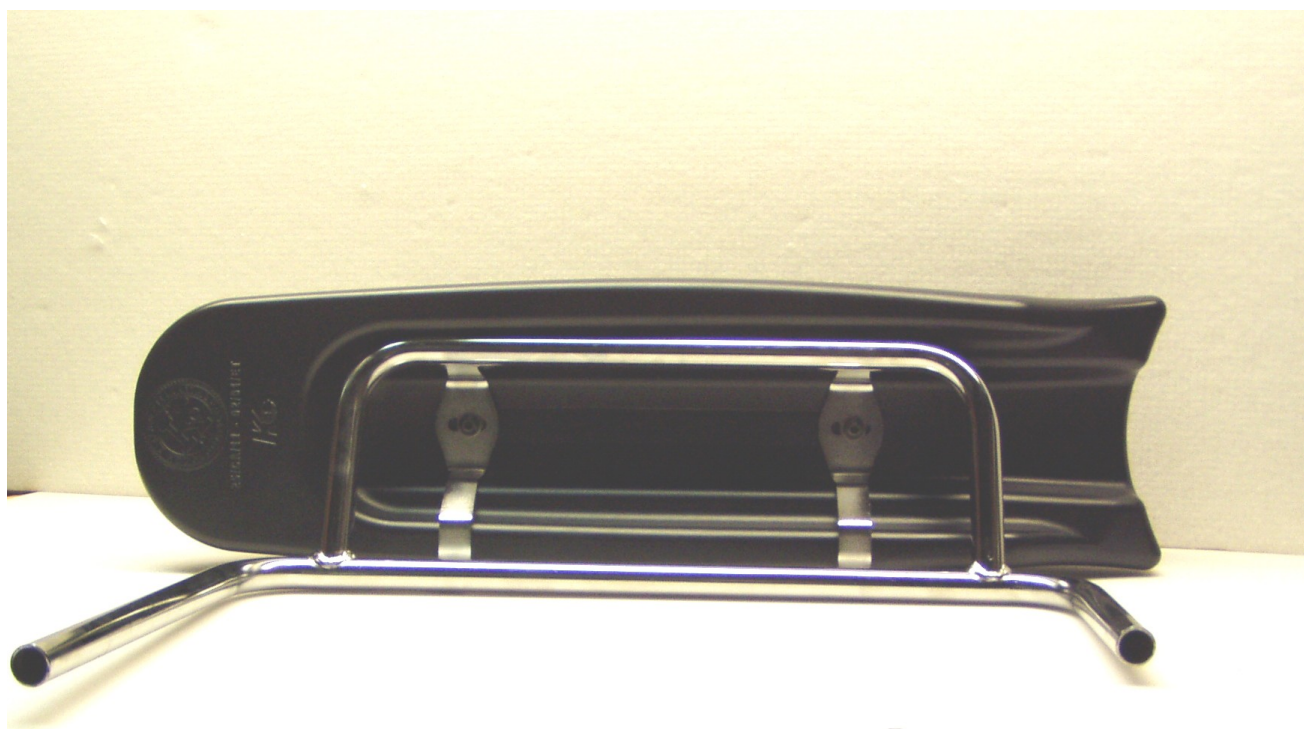

PHOTO AVEC SUPPORT / WITH SUPPORTS



<b>25/CA/11</b> <b>02/02/ET</b>
------------------------------------

PHOTO DU MARQUAGE DU NUMERO D'HOMOLOGATION  
**PHOTO OF THE HOMOLOGATION NUMBER MARKING**

**Le marquage doit rester clairement visible en permanence**  
**The marking must be clearly visible at all times**

CARÉNAGE AVANT ET SUPPORTS

*FRONT FAIRING AND SUPPORTS*

PANNEAU FRONTAL

*FRONT PANEL*

CARROSSERIE LATÉRALE ET SUPPORTS

*LATERAL BODYWORK AND SUPPORTS*

